

ELECTRONIC DEVICES AND CIRCUIT THEORY

TENTH EDITION

BOYLESTAD



PEARSON

Chapter 12 Power Amplifiers

Definitions

In small-signal amplifiers the main factors are:

- **Amplification**
- **Linearity**
- **Gain**

Since large-signal, or power, amplifiers handle relatively large voltage signals and current levels, the main factors are:

- **Efficiency**
- **Maximum power capability**
- **Impedance matching to the output device**

Amplifier Types

Class A

The amplifier conducts through the full 360° of the input. The Q-point is set near the middle of the load line.

Class B

The amplifier conducts through 180° of the input. The Q-point is set at the cutoff point.

Class AB

This is a compromise between the class A and B amplifiers. The amplifier conducts somewhere between 180° and 360° . The Q-point is located between the mid-point and cutoff.

[more...](#)

Amplifier Types

Class C

The amplifier conducts less than 180 of the input. The Q-point is located below the cutoff level.

Class D

This is an amplifier that is biased especially for digital signals.

Class A Amplifier

The output of a class A amplifier conducts for the full 360° of the cycle.

The Q-point is set at the middle of the load line so that the AC signal can swing a full cycle.

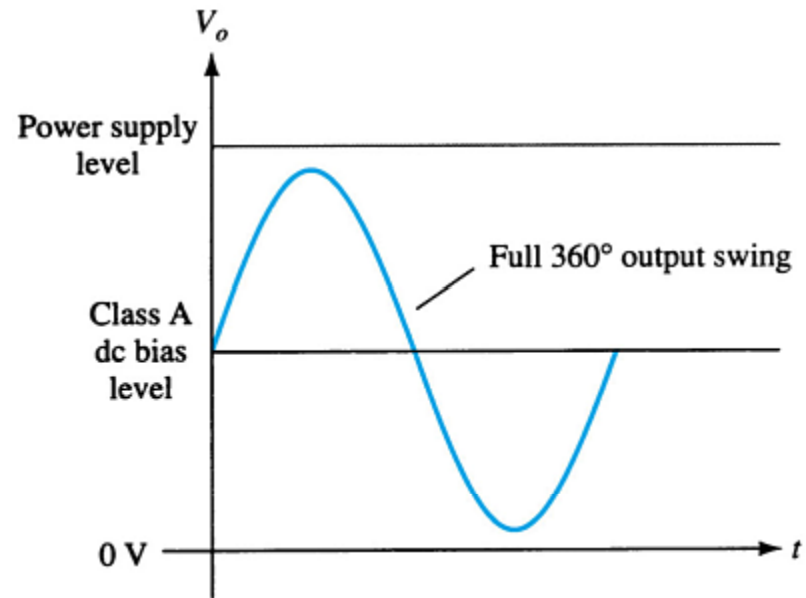
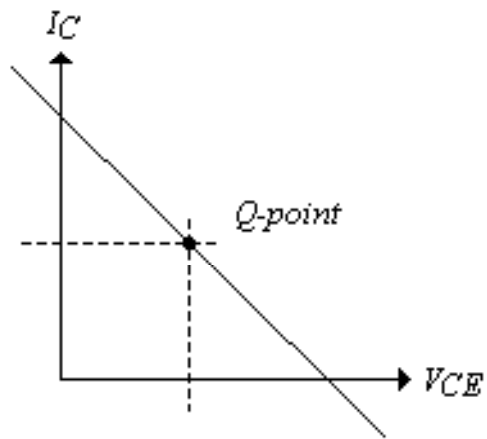

Remember that the DC load line indicates the maximum and minimum limits set by the DC power supply.

Class B Amplifier

A class B amplifier output only conducts for 180° or one-half of the AC input signal.

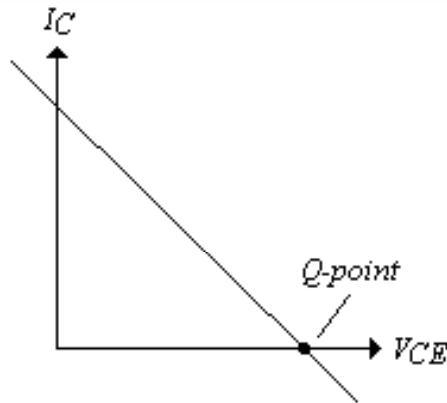
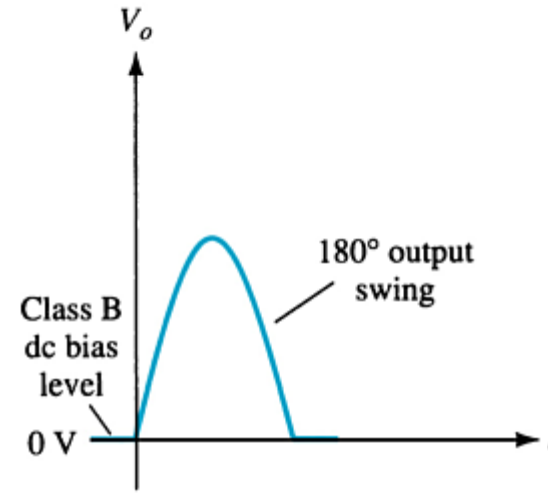

The Q-point is at 0V on the load line, so that the AC signal can only swing for one-half cycle.

Class AB Amplifier

This amplifier is a compromise between the class A and class B amplifier—the Q-point is above that of the Class B but below the class A.

The output conducts between 180° and 360° of the AC input signal.

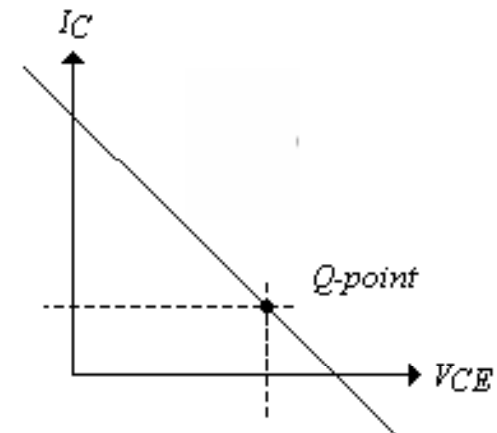

Class C

The output of the class C conducts for less than 180° of the AC cycle. The Q-point is below cutoff.

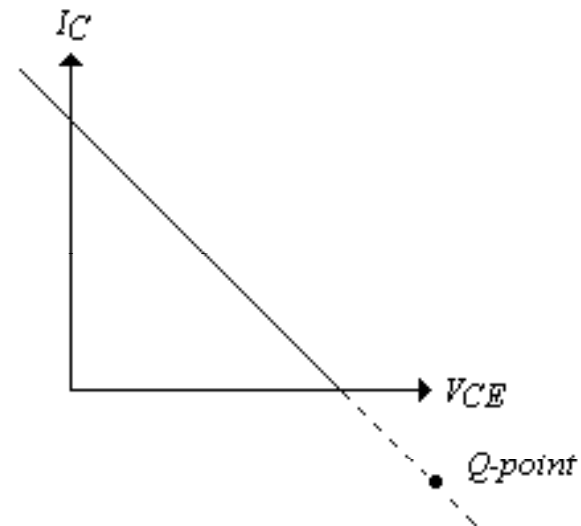

Amplifier Efficiency

Comparison of Amplifier Classes					
	A	AB	Class B	C*	D
Operating cycle	360°	180° to 360°	180°	Less than 180°	Pulse operation
Power efficiency	25% to 50%	Between 25% (50%) and 78.5%	78.5%		Typically over 90%

**Class C is usually not used for delivering large amounts of power, thus the efficiency is not given here.*

Efficiency refers to the ratio of output to input power. The lower the amount of conduction of the amplifier the higher the efficiency.

Series-Fed Class A Amplifier

This is similar to the small-signal amplifier except that it will handle higher voltages. The transistor used is a high-power transistor.

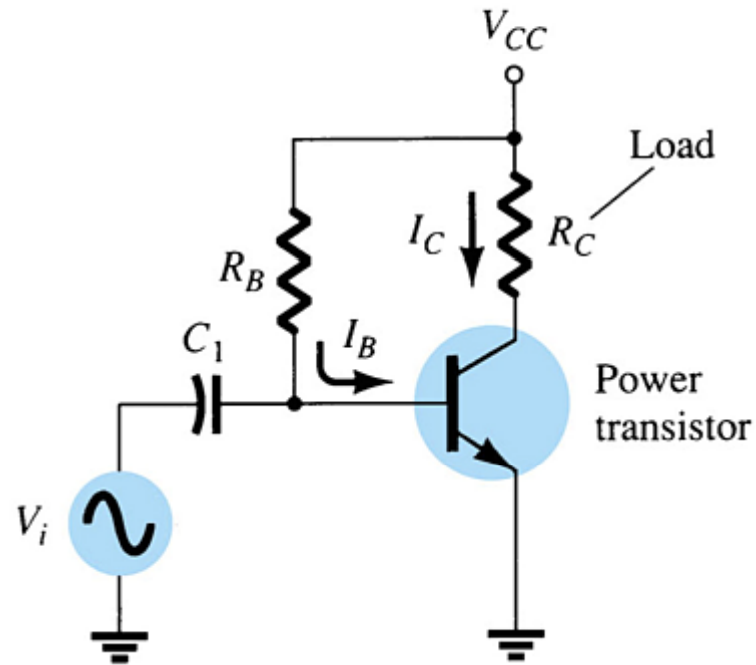

Series-Fed Class A Amplifier

A small input signal causes the output voltage to swing to a maximum of V_{CC} and a minimum of 0V. The current can also swing from 0mA to I_{CSAT} (V_{CC}/R_C)

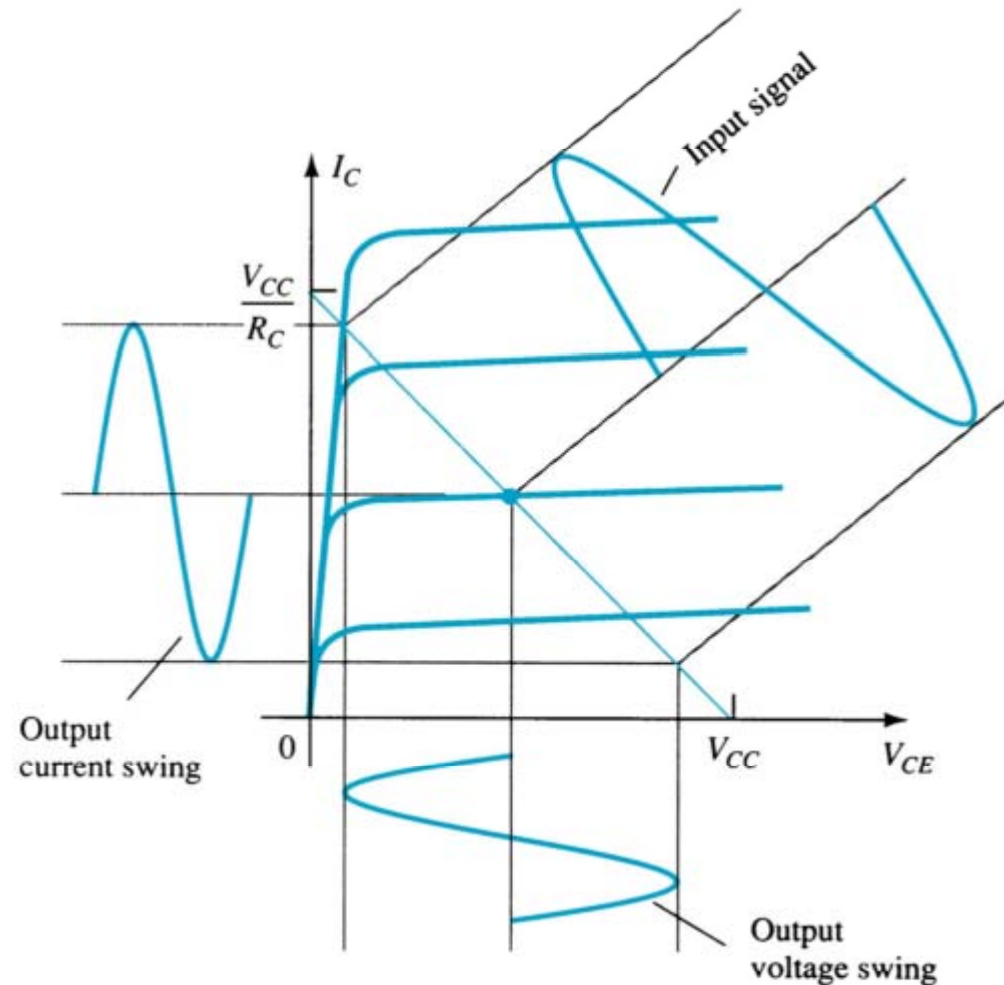

Series-Fed Class A Amplifier

Input Power

The power into the amplifier is from the DC supply. With no input signal, the DC current drawn is the collector bias current, I_{CQ} .

$$P_{i(dc)} = V_{CC}I_{CQ}$$

Output Power

$$P_{o(ac)} = \frac{V_{C(rms)}^2}{R_C} \quad \text{or} \quad P_{o(ac)} = \frac{V_{CE(p-p)}^2}{8R_C}$$

Efficiency

$$\% \eta = \frac{P_{o(ac)}}{P_{i(ac)}} \times 100$$

Transformer-Coupled Class A Amplifier

This circuit uses a transformer to couple to the load. This improves the efficiency of the Class A to 50%.

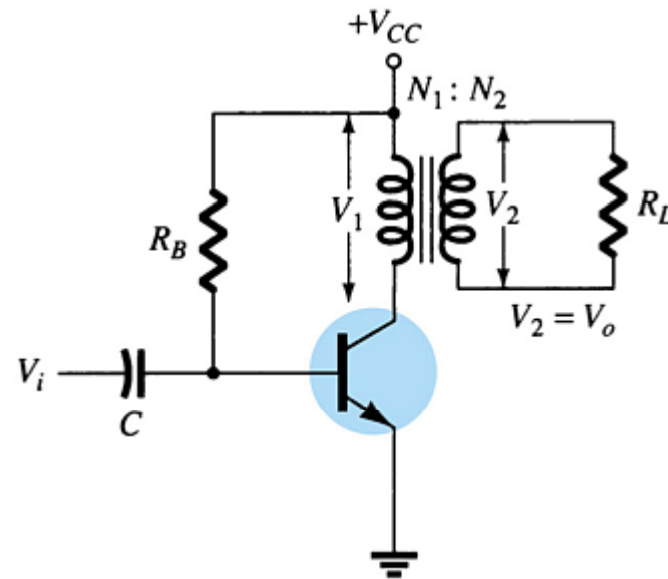

Transformer Action

A transformer improves the efficiency because it is able to transform the voltage, current, and impedance

Voltage Ratio

$$\frac{V_2}{V_1} = \frac{N_2}{N_1}$$

Current Ratio

$$\frac{I_2}{I_1} = \frac{N_1}{N_2}$$

Impedance Ratio

$$\frac{R'_L}{R_L} = \frac{R_1}{R_2} = \left(\frac{N_1}{N_2}\right)^2 = a^2$$

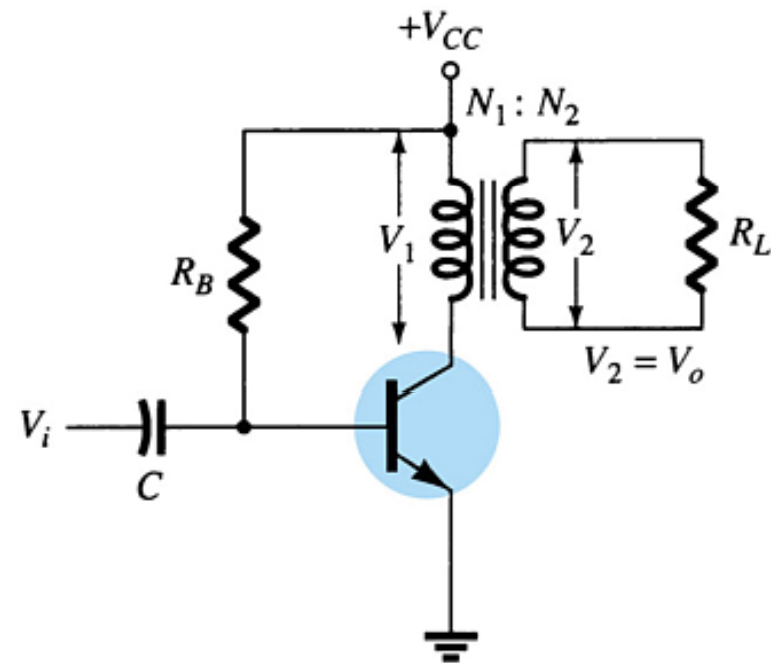

Transformer-Coupled Class A Amplifier

DC Load Line

As in all class A amplifiers the Q-point is established close to the midpoint of the DC load line.

AC Load Line

The saturation point (I_{Cmax}) is at V_{cc}/R'_L and the cutoff point is at V_2 (the secondary voltage of the transformer). This increases the maximum output swing because the minimum and maximum values of I_C and V_{CE} are spread further apart.

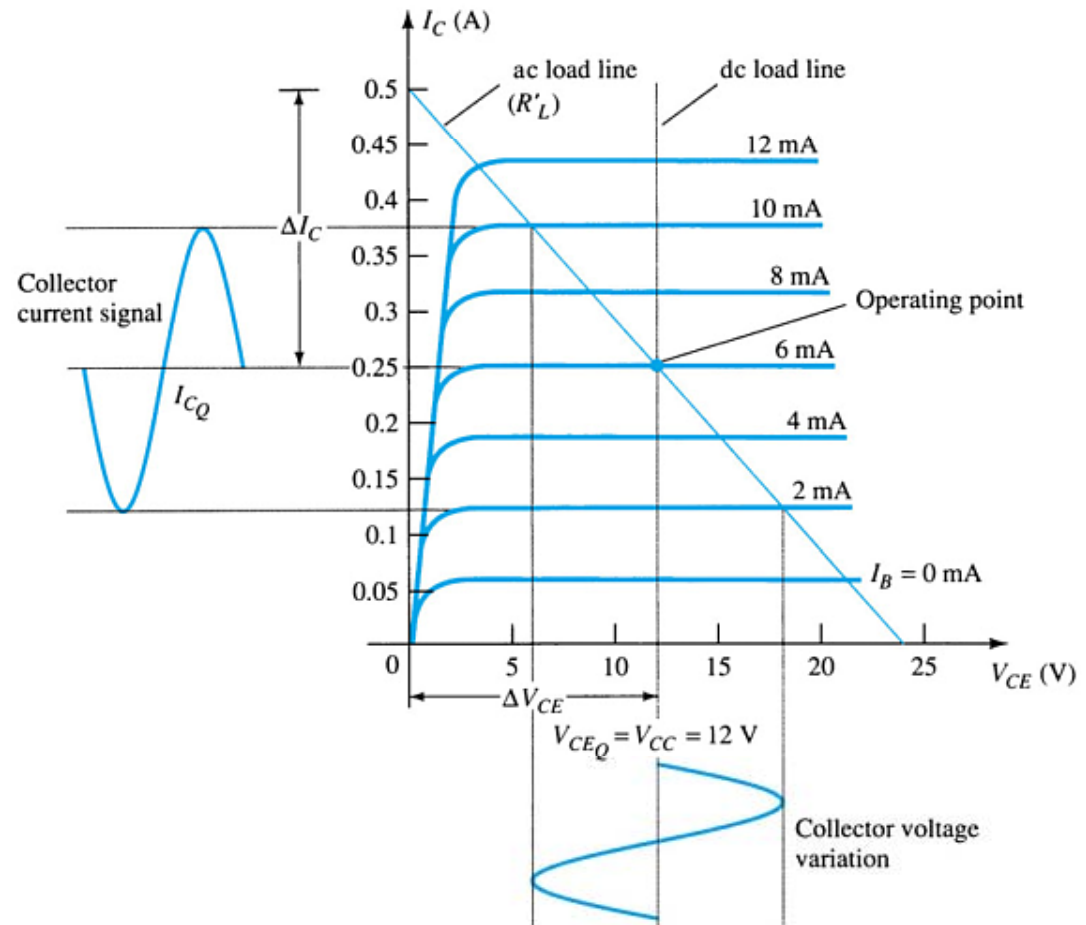

Transformer-Coupled Class A Amplifier

Signal Swing and Output AC Power

The voltage swing:

$$V_{CE(p-p)} = V_{CE\max} - V_{CE\min}$$

The current swing:

$$I_{C\max} - I_{C\min}$$

The AC power:

$$P_{o(ac)} = \frac{(V_{CE\max} - V_{CE\min})(I_{C\max} - I_{C\min})}{8}$$

Transformer-Coupled Class A Amplifier Efficiency

Power input from the DC source:

$$P_{i(dc)} = V_{CC}I_{CQ}$$

Power dissipated as heat across the transistor:

$$P_Q = P_{i(dc)} - P_{o(ac)}$$

Note: The larger the input and output signal, the lower the heat dissipation.

Maximum efficiency:

$$\% \eta = 50 \left(\frac{V_{CEmax} - V_{CEmin}}{V_{CEmax} + V_{CEmin}} \right)^2$$

Note: The larger V_{CEmax} and smaller V_{CEmin} , the closer the efficiency approaches the theoretical maximum of 50%.

Class B Amplifier

In class B, the transistor is biased just off. The AC signal turns the transistor on.

The transistor only conducts when it is turned on by one-half of the AC cycle.

In order to get a full AC cycle out of a class B amplifier, you need two transistors:

- An *npn* transistor that provides the negative half of the AC cycle
- A *pnp* transistor that provides the positive half.

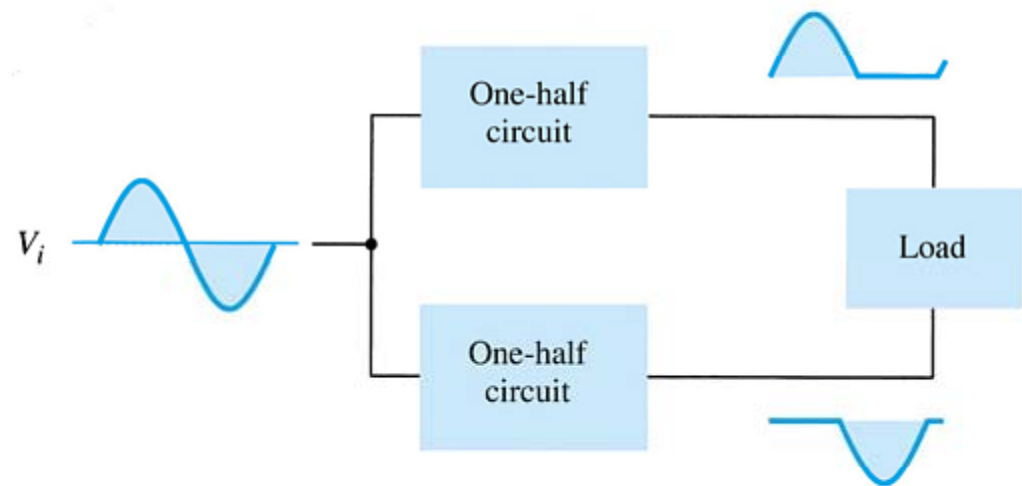

Class B Amplifier: Efficiency

The maximum efficiency of a class B is 78.5%..

$$\% \eta = \frac{P_{o(ac)}}{P_{i(dc)}} \times 100$$

$$\text{maximum } P_{o(dc)} = \frac{V_{CC}^2}{2R_L}$$

For maximum power, $V_L = V_{CC}$

$$\text{maximum } P_{i(dc)} = V_{CC}(\text{maximum } I_{dc}) = V_{CC} \left(\frac{2V_{CC}}{\pi R_L} \right) = \frac{2V_{CC}^2}{\pi R_L}$$

Transformer-Coupled Push-Pull Class B Amplifier

The center-tapped transformer on the input produces opposite polarity signals to the two transistor inputs.

The center-tapped transformer on the output combines the two halves of the AC waveform together.

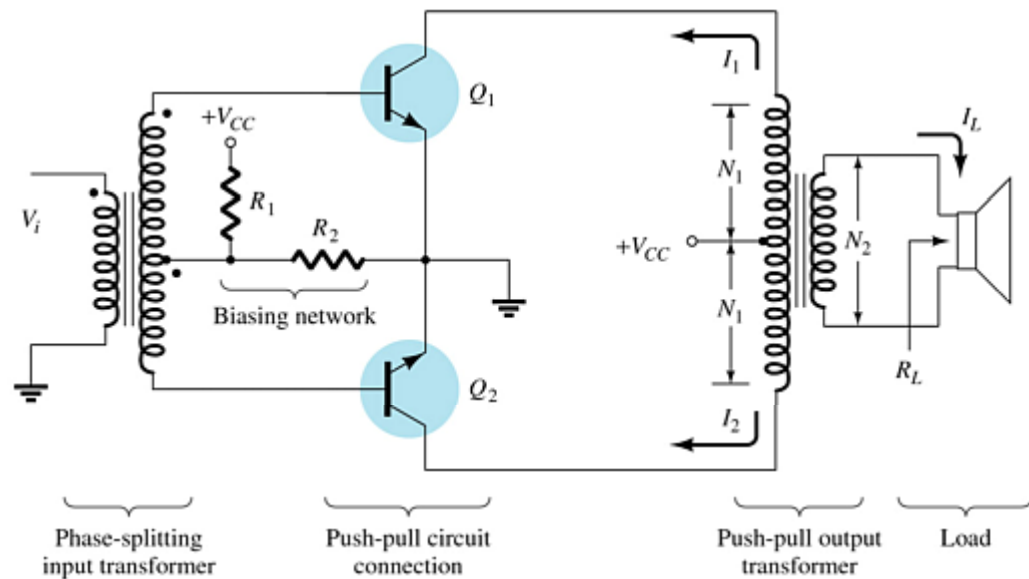

Class B Amplifier Push-Pull Operation

- During the positive half-cycle of the AC input, transistor Q_1 (*nnp*) is conducting and Q_2 (*ppn*) is off.
- During the negative half-cycle of the AC input, transistor Q_2 (*ppn*) is conducting and Q_1 (*nnp*) is off.

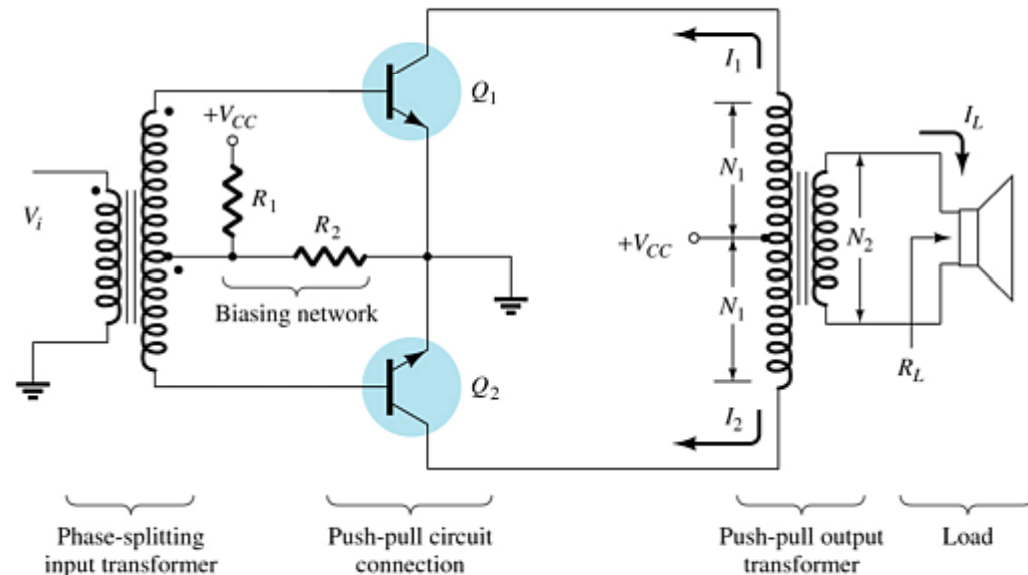

Each transistor produces one-half of an AC cycle. The transformer combines the two outputs to form a full AC cycle.

Crossover Distortion

If the transistors Q_1 and Q_2 do not turn on and off at exactly the same time, then there is a gap in the output voltage.

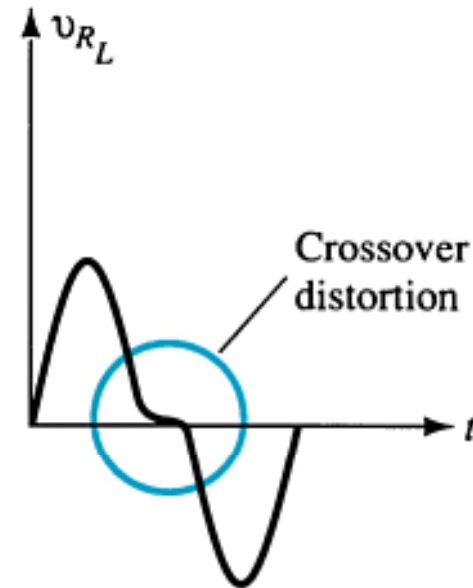

Quasi-Complementary Push-Pull Amplifier

A Darlington pair and a feedback pair combination perform the push-pull operation. This increases the output power capability.

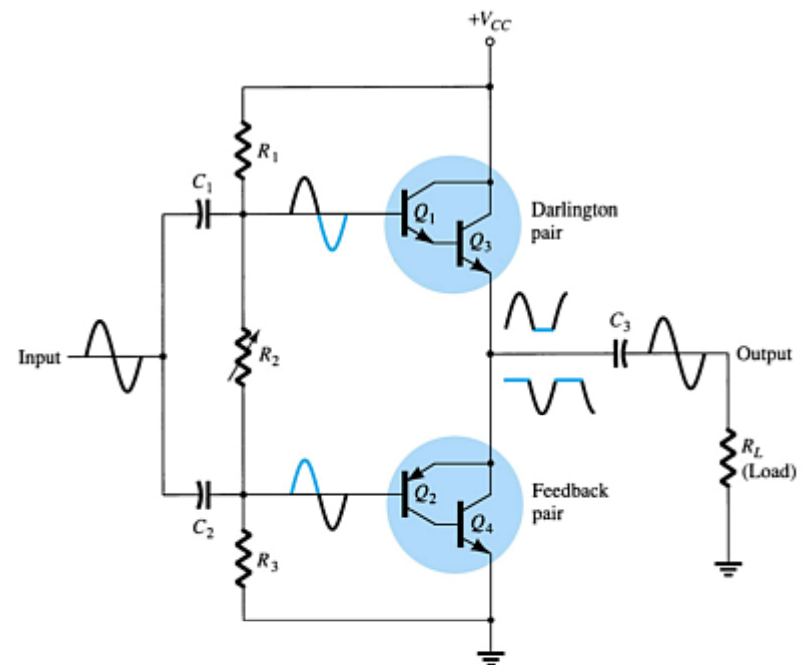

Amplifier Distortion

If the output of an amplifier is not a complete AC sine wave, then it is distorting the output. The amplifier is non-linear.

This distortion can be analyzed using Fourier analysis. In Fourier analysis, any distorted periodic waveform can be broken down into frequency components. These components are harmonics of the fundamental frequency.

Harmonics

Harmonics are integer multiples of a fundamental frequency.

If the fundamental frequency is 5kHz:

1st harmonic	1 x 5kHz
2nd harmonic	2 x 5kHz
3rd harmonic	3 x 5kHz
4th harmonic	4 x 5kHz
etc.	

Note that the 1st and 3rd harmonics are called **odd harmonics and the 2nd and 4th are called **even harmonics**.**

Harmonic Distortion

According to Fourier analysis, if a signal is not purely sinusoidal, then it contains harmonics.

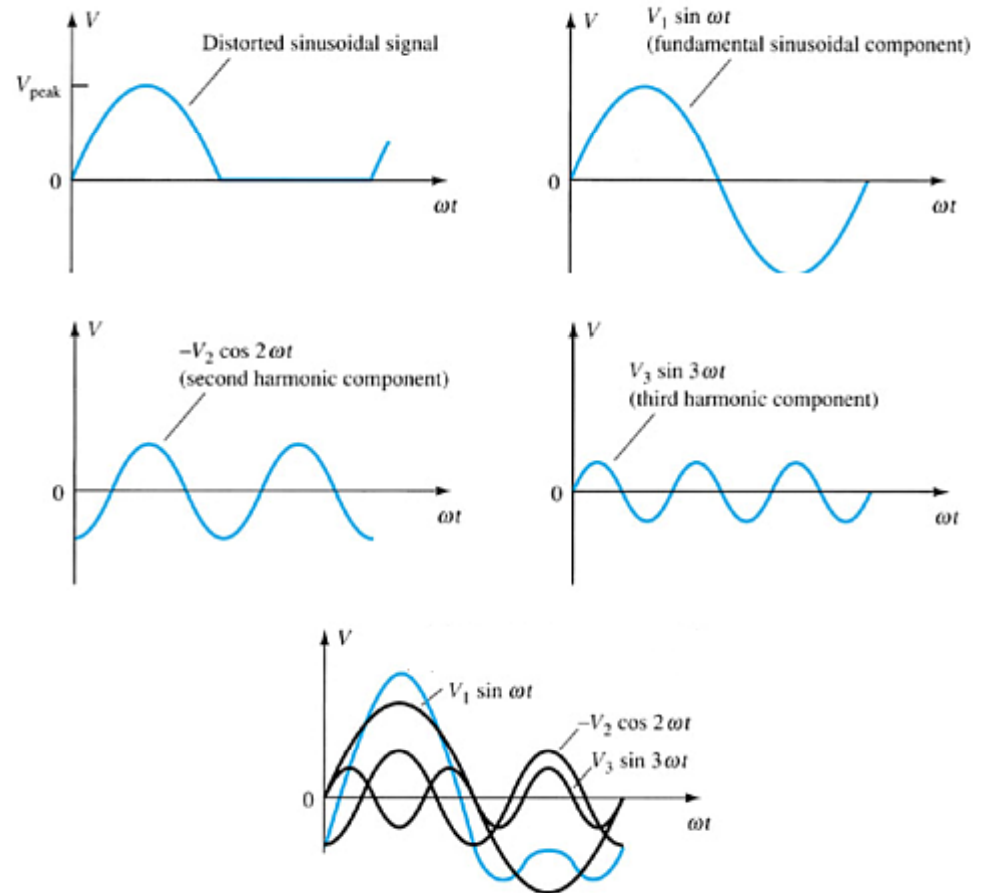

Harmonic Distortion Calculations

Harmonic distortion (**D**) can be calculated:

$$\% \text{ nth harmonic distortion} = \%D_n = \left| \frac{A_n}{A_1} \right| \times 100$$

where

A_n is the amplitude of the fundamental frequency

A_n is the amplitude of the highest harmonic

The total harmonic distortion (THD) is determined by:

$$\% \text{ THD} = \sqrt{D_2^2 + D_3^2 + D_3^2 + \dots} \times 100$$

Power Transistor Derating Curve

Power transistors dissipate a lot of power in heat. This can be destructive to the amplifier as well as to surrounding components.

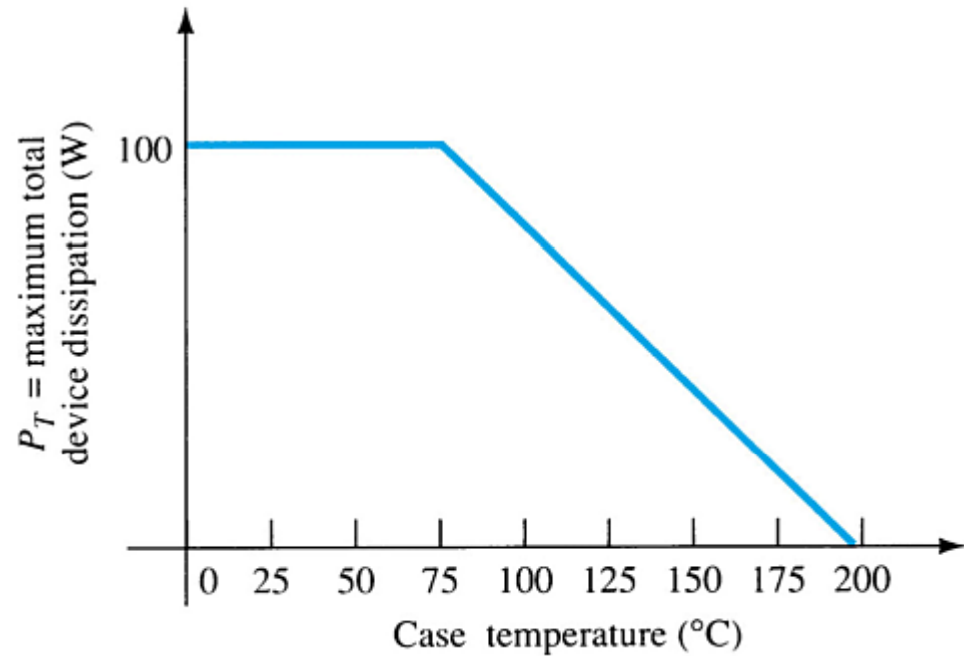

Class C Amplifiers

A class C amplifier conducts for less than 180° . In order to produce a full sine wave output, the class C uses a tuned circuit (LC tank) to provide the full AC sine wave.

Class C amplifiers are used extensively in radio communications circuits.

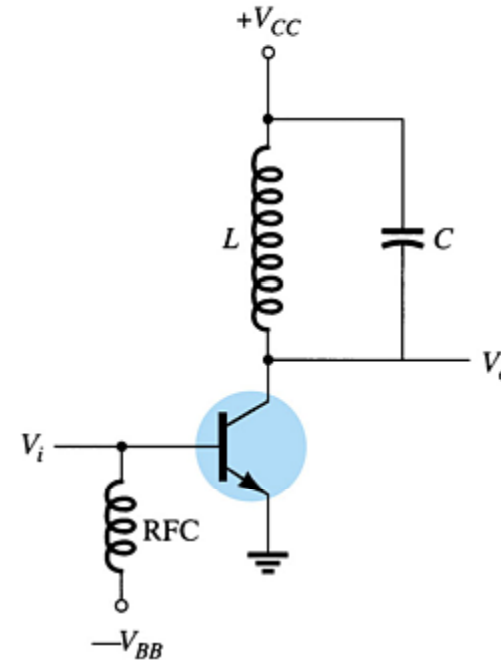

Class D Amplifier

A class D amplifier amplifies pulses, and requires a pulsed input.

There are many circuits that can convert a sinusoidal waveform to a pulse, as well as circuits that convert a pulse to a sine wave. This circuit has applications in digital circuitry.

